

No.	Revision	Date	Name
▲	PN Change from 1A-454-00	22/OCT/2013	S.J.PARK
▲			

RoHS Compliant

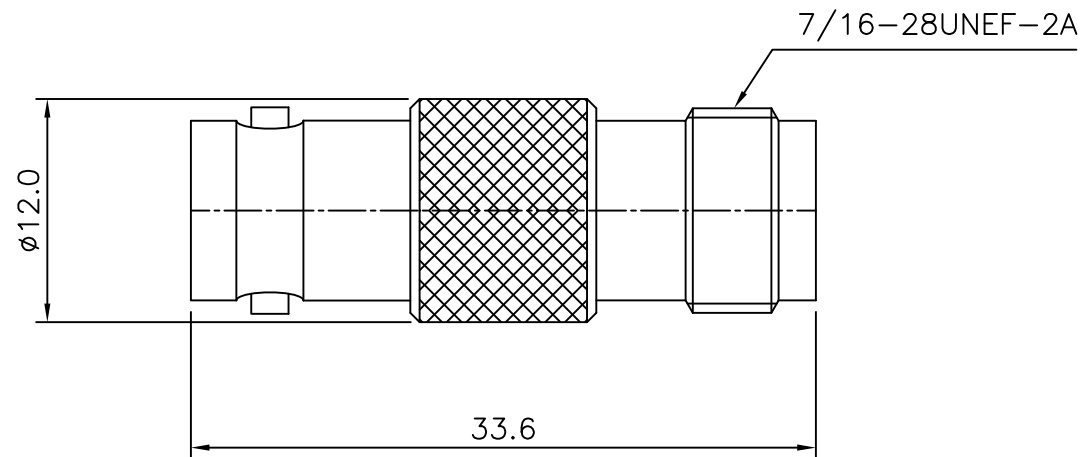

BNC JACK TO TNC JACK  
-ADAPTOR

Item	Materials	Plating
Body	Brass	Nickel Plated
Center contact	Beryllium copper	Gold Plated
Insulator	PTFE	-

NO.	DESCRIPTION	Q'TY	MATERIAL	FINISH	REMARKS.
PARTS No.	AD-1921-401	NAME	BNCJ-TNCJ ADAP.		APPROVED
MATERIAL	FINISH	TOLERANCES OTHERWISE SPEC. ±0.05		ANGLES ±1°	CHECKED
SCALE		UNIT	mm		DESIGNED S.J.LEE
DWG NO.		AD-1921-401		DATE. 27/JUL/2010	

**CUSTOMER**



DONGJIN TI.