

1	2	3	4	5	6
No.	Revision		Date	Name	
△	PN Change from 1B-322-002		09/APR/2014	S.J.PARK	
△					

RoHS Compliant

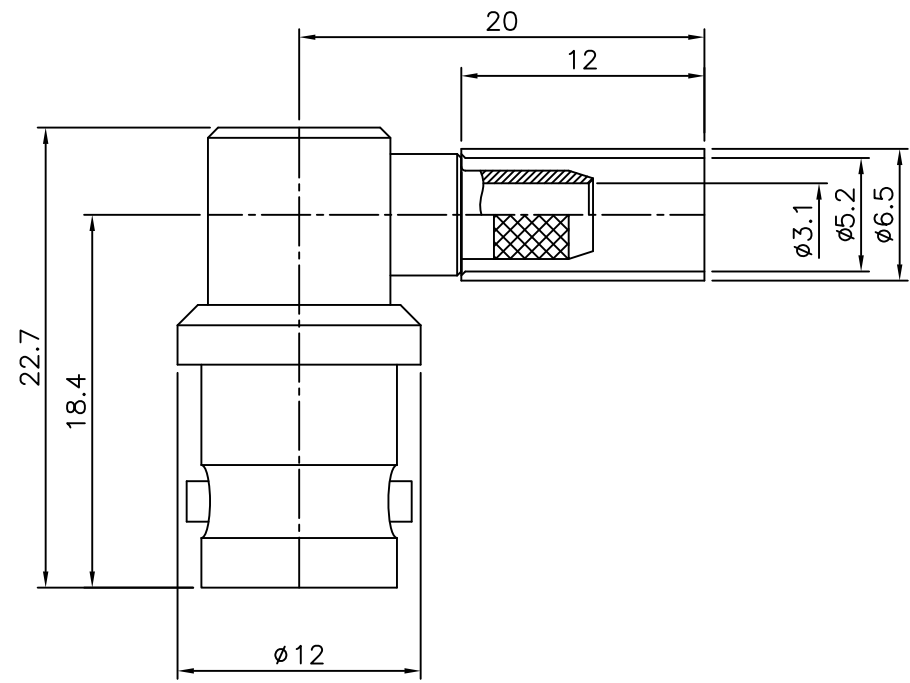

BNC Right Angle-JACK  
for Cable-RG58

Connector parts	Materials	Finish
Body	Brass	Nickel Plated
Center contact	Be-Cu	Gold Plated
Insulator	PTFE	-
Ferrule	Brass	Nickel Plated

**CUSTOMER**

NO.	DESCRIPTION	Q'TY	MATERIAL	FINISH	REMARKS.
PARTS No.	BNC-312-005	NAME	BNC-RA JACK58		APPROVED
MATERIAL	FINISH	TOLERANCES OTHERWISE SPEC. ±0.05		ANGLES ±1°	CHECKED
SCALE		UNIT	mm		DESIGNED S.J.LEE
DWG NO.		BNC-312-005		DATE.	25/FEB/2005

