

4	No.	Revision	Date	Name
	△	PN Change from 1B-415-00	09/APR/2014	S.J.PARK
	△			

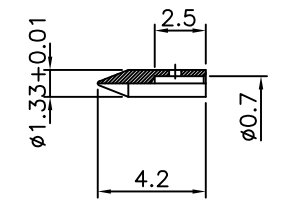
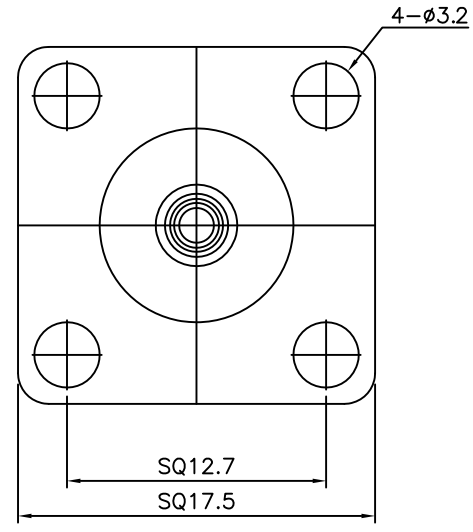
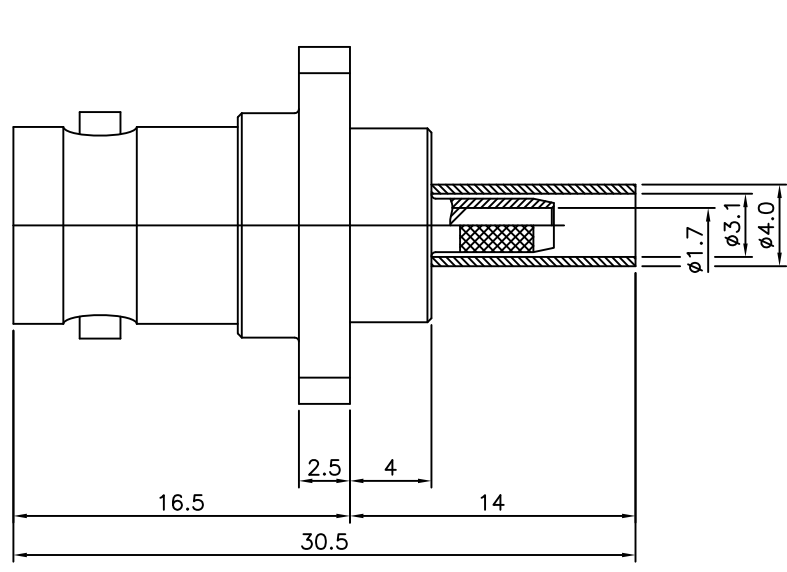

Item	Materials	Plating
Body	Brass	Nickel Plated
Center contact	Be-Cu	Gold Plated
Insert pin	Brass	Gold Plated
Insulator	PTFE	-

BNC-PANEL 4HOLES JACK
for Cable-RG316

NO.	DESCRIPTION	Q'TY	MATERIAL	FINISH	REMARKS.
PARTS No.	BNC-411-008	NAME	BNC-4H JACK RG316		APPROVED
MATERIAL	FINISH	TOLERANCES OTHERWISE SPEC. ±0.05		ANGLES ±1°	CHECKED
SCALE		UNIT	mm		DESIGNED S.J.LEE
DWG NO.		BNC-411-008		DATE.	18/SEP/2007

CUSTOMER

