

4	5	6	
No.	Revision	Date	Name
△	PN Change from 1B-710-00	17/FEB/2014	B.G.YUN
△			

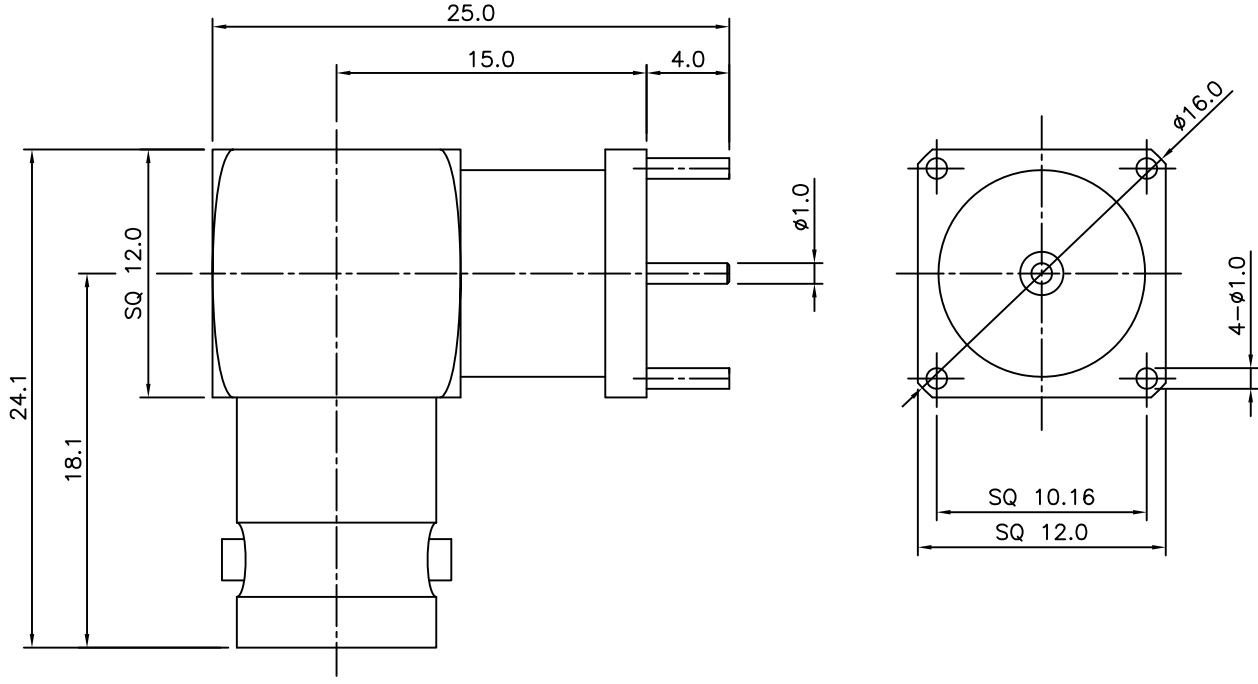

BNC-RIGHT Angle JACK
PCB Mount-50 OHm

Item	Materials	Plating
Body	Brass	Nickel Plated
Center contact	Be-Cu	Gold Plated
Mounting Pin	Brass	Nickel Plated
Insulator	TEFLON	-

CUSTOMER

NO.	DESCRIPTION	Q'TY	MATERIAL	FINISH	REMARKS.
PARTS No.	BNC-608-001	NAME	BNC-LJ-PCB		APPROVED
MATERIAL	FINISH	TOLERANCES OTHERWISE SPEC. ±0.05		ANGLES ±1°	CHECKED
		SCALE	UNIT mm		DESIGNED S.J.LEE
		DWG NO. BNC-608-001		DATE. 15/DEC/2008	