

1                      2                      3                      4                      5                      6

No.	Revision	Date	Name
△	PN Change from 1N-806-00	19/MAY/2014	S.J.PARK
△			

NOTES.  
 Working frequency; DC~9GHz  
 Handling Power; 100 watt  
 VSWR; 1.25:1

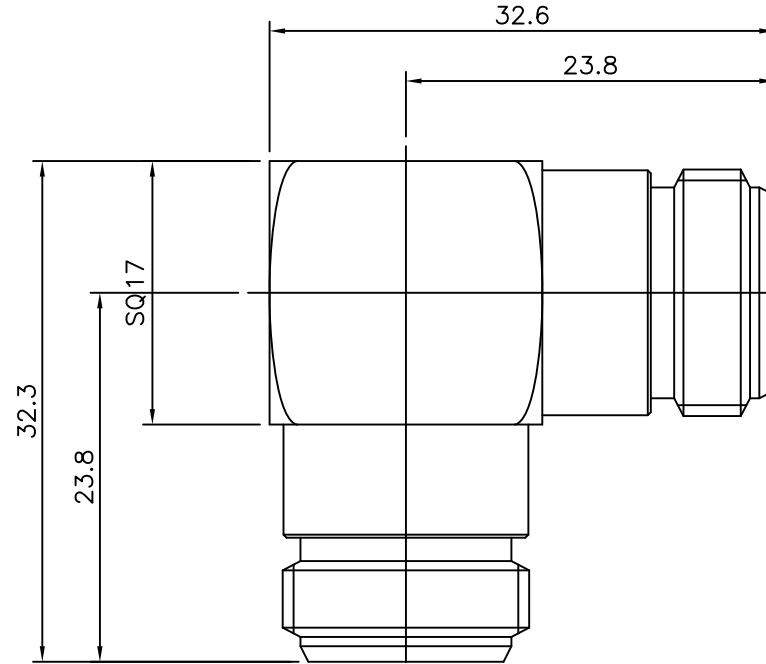

N-Right angle JACK  
 TO JACK ADAPTOR

Item	Materials	Plating
Body	Brass	Nickel Plated
Center contact	Be-Cu	Gold Plated
Insulator	PTFE	-

NO.	DESCRIPTION	Q'TY	MATERIAL	FINISH	REMARKS.
PARTS No.	N-806-002		NAME	N-RA JJ ADAPTOR	APPROVED
MATERIAL	FINISH	TOLERANCES OTHERWISE SPEC. ±0.05		ANGLES ±1°	CHECKED
SCALE		UNIT	mm		DESIGNED S.J.LEE
DWG NO.		N-806-002		DATE. 2001.5/04	

CUSTOMER

