

4	5	6
No.	Revision	Date
△		
△		

RoHS Compliant

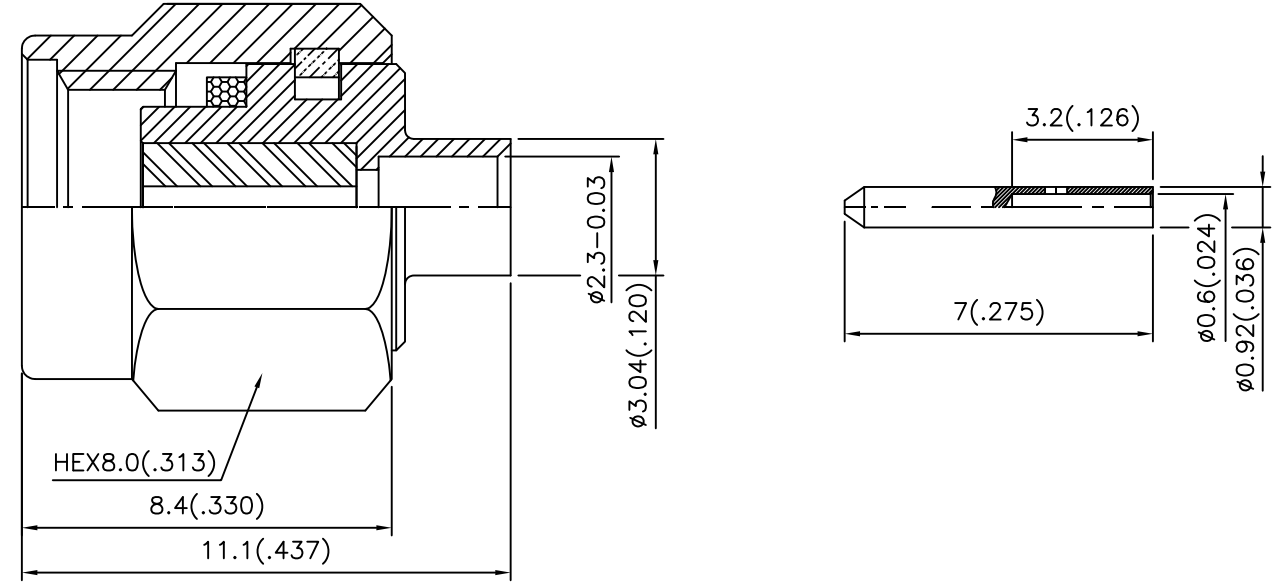

Connector parts	Materials	Finish
Coupling Cap	Stainless steel 303	Passivated
Body	Brass	Gold Plate per Mil G45204 Type II, Grade C Class 1 over Low stress Sulfamate Nickel per QQN290 Class 2 over Copper Flash Per-Mil-C-14550
Center contact	Beryllium Copper	Gold Plate per Mil-G-45204 Type II, Grade C Class 1 over Copper Flash Per-Mil-C-14550
Insulator	PTFE	-
Gasket	Silicone rubber	-

SMA-Straight-PLUG
For Cable RG405 THICK WALL

NO.	DESCRIPTION	Q'TY	MATERIAL	FINISH	REMARKS.
PARTS No.	SMA-101-017	NAME	SMA-SP-405		APPROVED S.J.LEE
MATERIAL	FINISH	TOLERANCES OTHERWISE SPEC. ±0.05		ANGLES ±1°	CHECKED
SCALE		UNIT	mm		DESIGNED S.J.PARK
DWG NO.		SMA-101-017		DATE.	16/JUL/2013

CUSTOMER

