

No.	Revision	Date	Name
△	PN Change from 1S-112-200	20/08/2013	B.G.YUN
△	Ferrule finish change from Nickel to Gold	20/08/2013	B.G.YUN

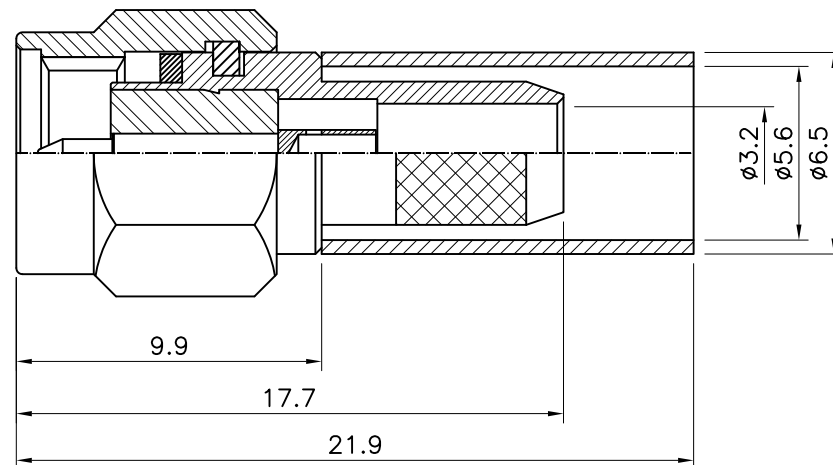

SMA-Stright-PLUG
for Cable: LMR200

Connector parts	Materials	Finish
Coupling Cap	Brass	Gold Plated
Body	Brass	Gold Plated
Center contact	Brass	Gold Plated
△ Ferrule	Brass	Gold Plated
Insulator	PTFE	-

NO.	DESCRIPTION	Q'TY	MATERIAL	FINISH	REMARKS.
PARTS No.	SMA-112-014		NAME	SMA-SP-LMR200	APPROVED
MATERIAL	FINISH	TOLERANCES OTHERWISE SPEC. ±0.05		ANGLES ±1°	CHECKED
SCALE		UNIT	DESIGNED		S.J.LEE
N/S		mm	DATE.		
DWG NO.		SMA-112-014		2002/9/24	

CUSTOMER



DONGJIN TI.