

4	5	6
No.	Revision	Date
△	PN Change from 1S-112RP-00	11/FEB/2014
△		
Name		Name
		S.J.PARK

D
C
B
A

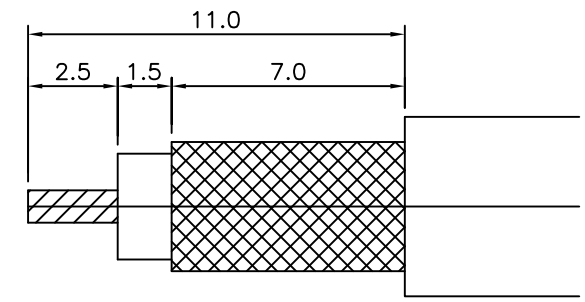
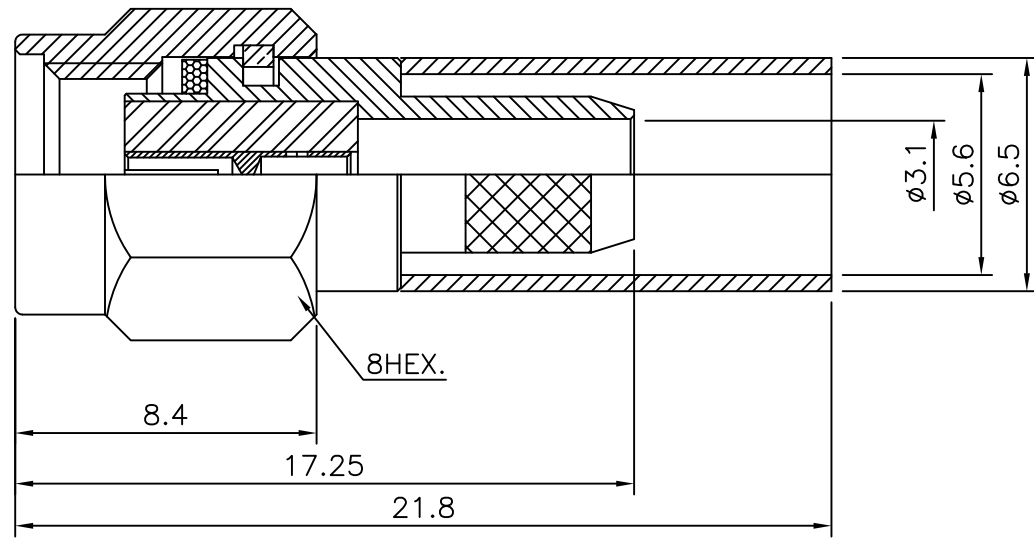

Recommended Stripping DIM'S
Recommended CRIMP DIES : HEX5.5

Connector parts	Materials	Finish
Coupling Cap	Brass	Gold Plated
Body	Brass	Gold Plated
Center contact	Be-Cu	Gold Plated
Ferrule	Brass	Gold Plated
Insulator	PTFE	-

SMA-Straight-PLUG,CRIMP
REVERSE POLARITY
for Cable:RG-RG400,223

CUSTOMER

NO.	DESCRIPTION	Q'TY	MATERIAL	FINISH	REMARKS.
PARTS No.	SMA-112-027		NAME	SMA-SP 400 RP	APPROVED
MATERIAL	FINISH	TOLERANCES OTHERWISE SPEC. ±0.05		ANGLES ±1°	CHECKED
SCALE		UNIT	mm		DESIGNED S.J.LEE
DWG NO.		SMA-112-027		DATE. 2002/7/13	

