

4	No.	Revision	5	Date	6	Name
	△					
	△					

RoHS Compliant

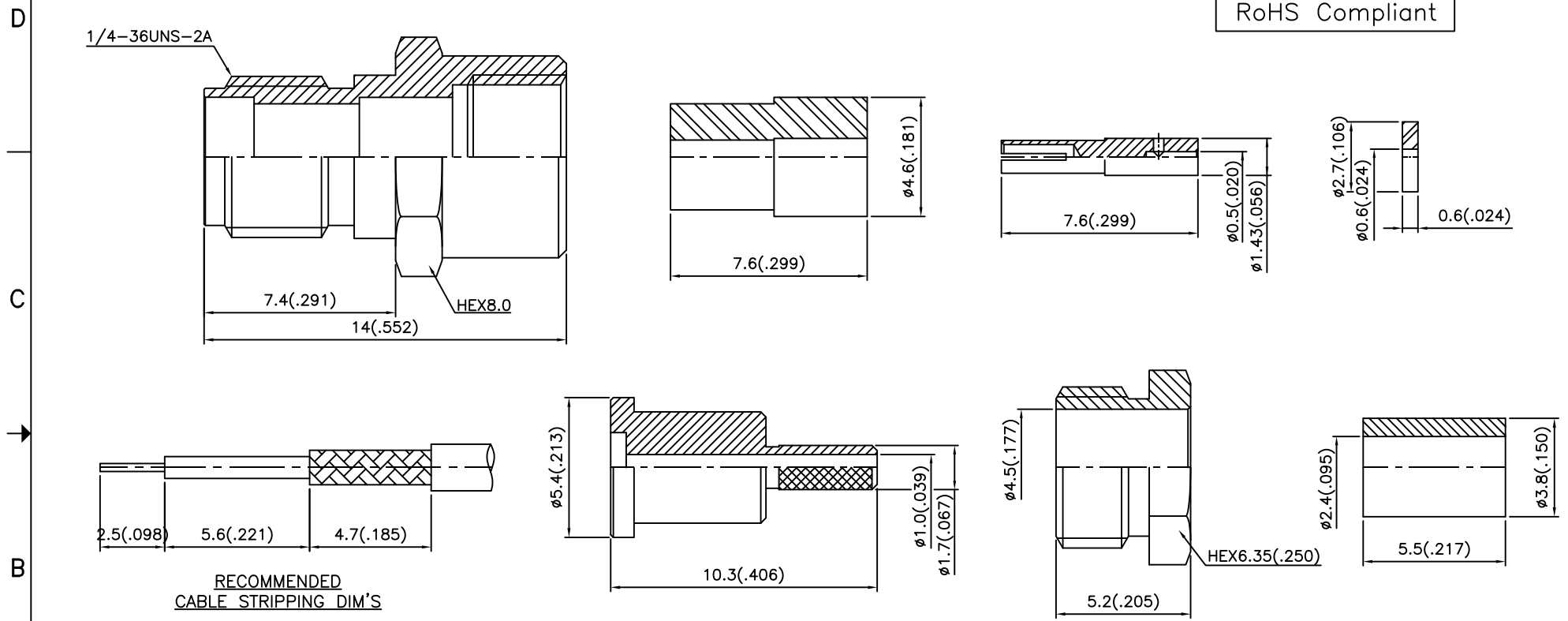

Connector parts	Materials	Finish
Body,Barrel,Nut	Brass	Gold Plated
Center contact	Beryllium copper	Gold Plated
Ferrule	Brass	Gold Plated
Insulator	PTFE	-

SMA-Stright-JACK
CRIMP for Cable:RG178

NO.	DESCRIPTION	Q'TY	MATERIAL	FINISH	REMARKS.
PARTS No.	SMA-210-001		NAME	SMA-SJ-178	APPROVED S.J.LEE
MATERIAL	FINISH	TOLERANCES OTHERWISE SPEC. ±0.05		ANGLES ±1°	CHECKED
		SCALE N/S	UNIT mm		DESIGNED S.J.PARK
CUSTOMER		DWG NO.		SMA-210-001	DATE. 09/JUL/2013

