

No.	Revision	Date	Name
△			
△			

SPECIFICATIONS.

- 1.1 Impedance: 50ohm
- 1.2 Frequency Range: per cable per MIL-C-17
- 1.3 Working Voltage rating: 250 Vrms
- 1.4 Dielectric Withstanding Voltage: 750 Vrms
- 1.5 VSWR: 1.2:1 Max
- 1.6 Insulation Resistance: 5,000 megohms
- 1.7 Connector Durability: 500 mating
- 1.8 Temperature Range: -45°C~+155°C

RoHS Compliant

1/4-36UNS-2A

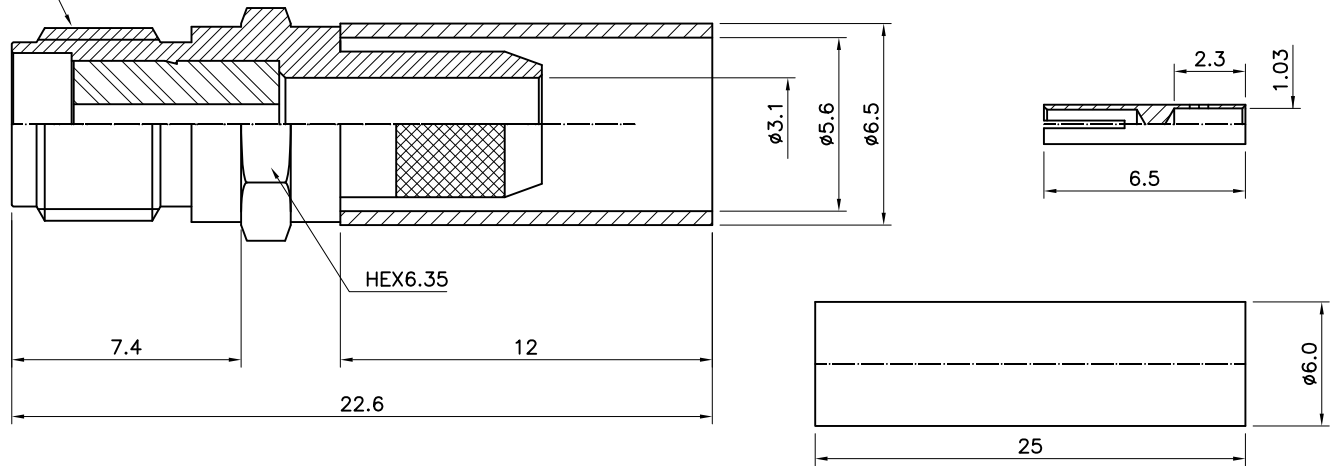

Heat shrink tube/GSHS-1625G Black

**SMA-Stright-JACK
for Cable:RG400**

Connector parts	Materials	Finish
Body	Stainless steel	Passivated
Center contact	Beryllium copper	Gold Plated
Ferrule	Brass	Nickel Plated
Insulator	PTFE	-
*Heat shrink tube	GSHS-1625G	-

CUSTOMER

NO.	DESCRIPTION	Q'TY	MATERIAL	FINISH	REMARKS.
PARTS No.	SMA-212-006		NAME	SMA-SJ-400	APPROVED S.J.LEE
MATERIAL	FINISH	TOLERANCES OTHERWISE SPEC. ±0.05		ANGLES ±1°	CHECKED
		SCALE N/S	UNIT mm		DESIGNED B.G.YUN
		DWG NO.		SMA-212-006	DATE. 07/AUG/2013



DONGJIN TI.