

| 4 | 5 | 6 | |
|-----|------------------------------|------------|---------|
| No. | Revision | Date | Name |
| △ | PN Change from 1S-504S-0051E | 02/07/2013 | B.G.YUN |
| △ | | | |

RoHS Compliant

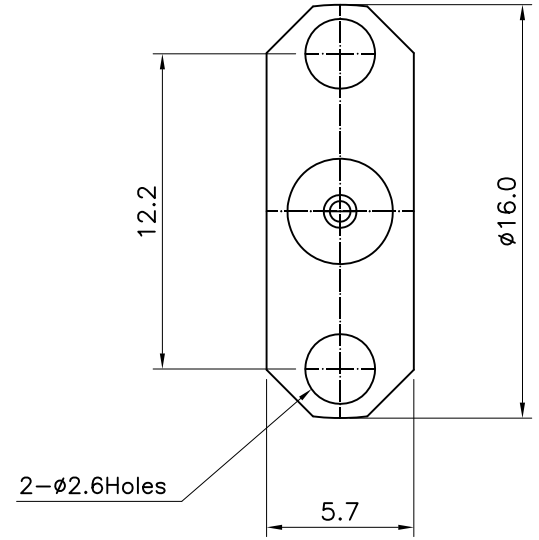
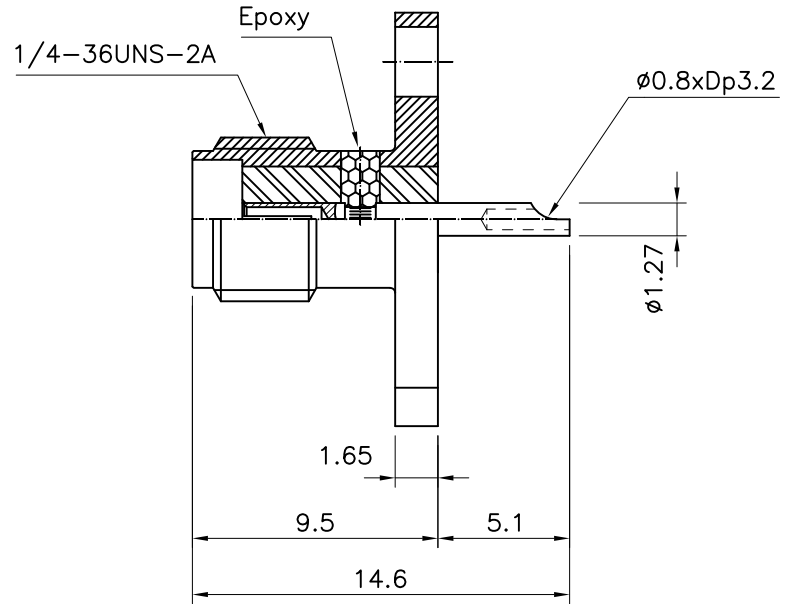

SMA-2H Flange Mount
JACK Receptacle/Solder pot

| Connector parts | Materials | Finish |
|-----------------|------------------|-------------|
| Body | Stainless steel | Passivated |
| Center contact | Beryllium copper | Gold Plated |
| Insulator | PTFE | - |

CUSTOMER

| NO. | DESCRIPTION | Q'TY | MATERIAL | FINISH | REMARKS. |
|-----------|-------------|----------------------------------|----------|------------------------|-------------------|
| PARTS No. | SMA-502-111 | | NAME | SMA-2H-JACK RECEPTACLE | APPROVED |
| MATERIAL | FINISH | TOLERANCES OTHERWISE SPEC. ±0.05 | | ANGLES ±1° | CHECKED |
| | | SCALE | UNIT | | DESIGNED S.J.LEE |
| | | | mm | | DATE. 29/MAY/2012 |
| | | DWG NO. | | SMA-502-111 | |