

4	No.	Revision	Date	Name
	▲	PN Change from 1S-542-S160	10/FEB/2014	S.J.PARK
	▲			

D
C
B
A

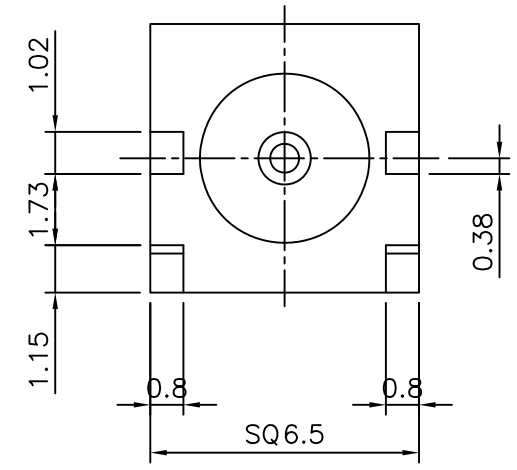
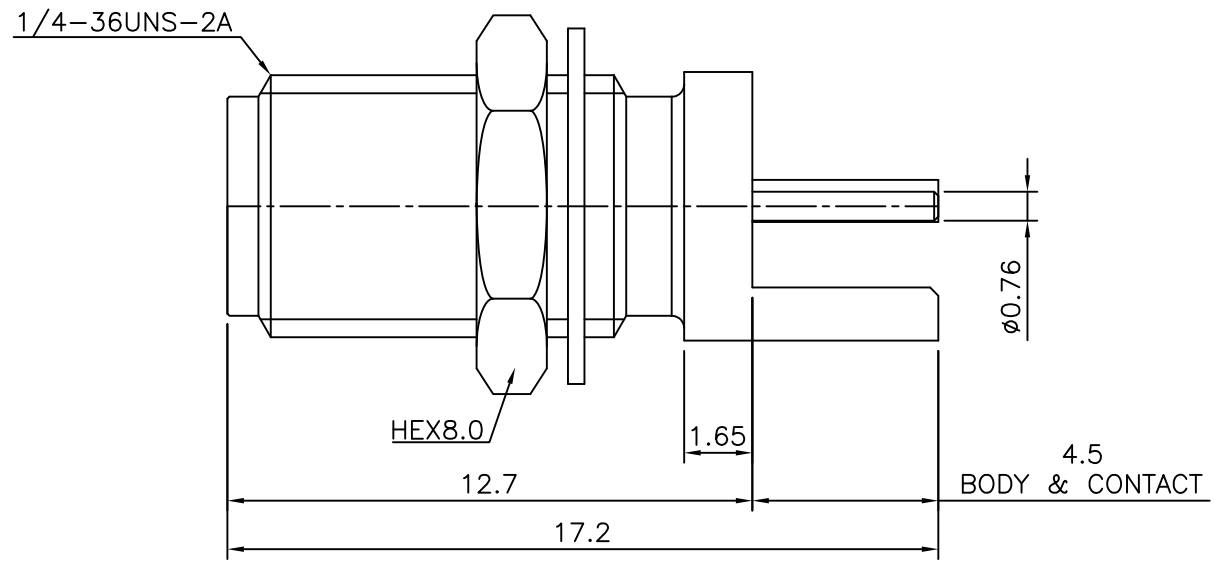

SMA End Launch Bulkhead Jack Receptacle
-Round Contact(1.60mm Board)

Connector parts	Materials	Finish
Body,Nut,Washer	Brass	Gold Plated
Center contact	BeCu	Gold Plated
Insulator	TEFLON	-

CUSTOMER

NO.	DESCRIPTION	Q'TY	MATERIAL	FINISH	REMARKS.
PARTS No.	SMA-604-003	NAME	SMA-Side/BJ-PCB		APPROVED
MATERIAL	FINISH	TOLERANCES OTHERWISE SPEC. ±0.05		ANGLES ±1°	CHECKED
		SCALE	UNIT mm		DESIGNED S.J.LEE
		DWG NO. SMA-604-003		DATE. 2003/1/10	