

4	No.	Revision	Date	Name
	△	PN Change from 1S-802-02	30/OCT/2013	S.J.PARK
	△			

RoHS Compliant

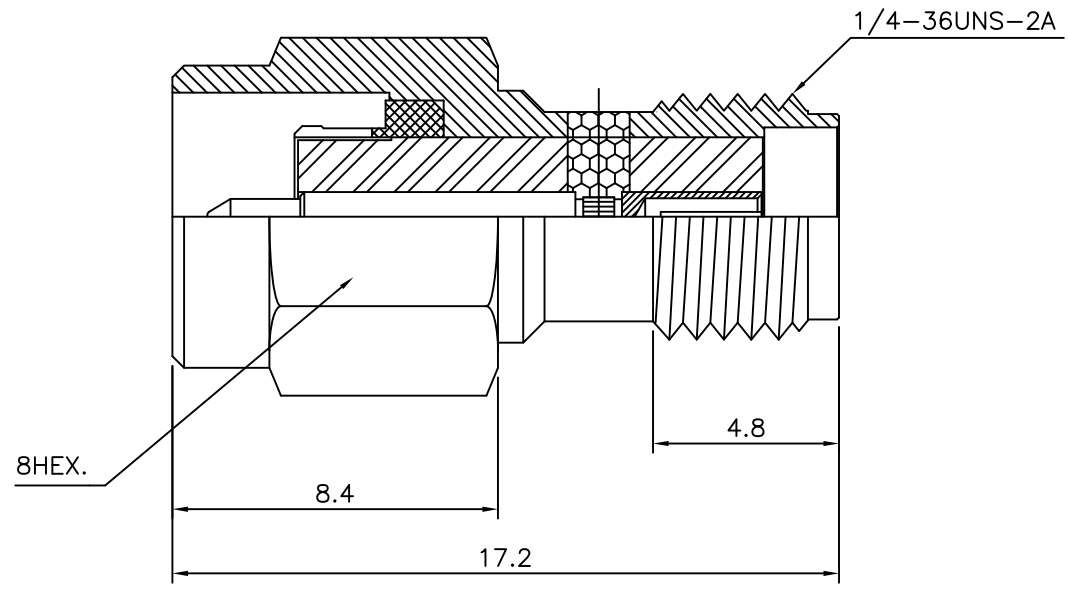

**Durability : 500 mating cycles.
 **V.S.W.R. : 1.12:1 max.@ 6.0GHz

SMA JACK to PLUG
 (SLIDE-ON)ADAPTOR

Connector parts	Materials	Finish
Body	Brass	Suico Plated
Center contact	Be-Cu	Gold Plated
Outer contact	Be-Cu	Gold Plated
Insulator	PTFE	-

NO.	DESCRIPTION	Q'TY	MATERIAL	FINISH	REMARKS.
PARTS No.	SMA-802-002		NAME	SMA/PJ-ADAPTOR	APPROVED
MATERIAL	FINISH	TOLERANCES OTHERWISE SPEC. ±0.05		ANGLES ±1°	CHECKED
SCALE		N/S	UNIT	mm	DESIGNED S.J.LEE
DWG NO.		SMA-802-002		DATE. 15/DEC/2008	

CUSTOMER

