

4	No.	Revision	Date	Name
	△	PN Change from 1S-882-00	S.J.PARK	11/FEB/2014
	△			

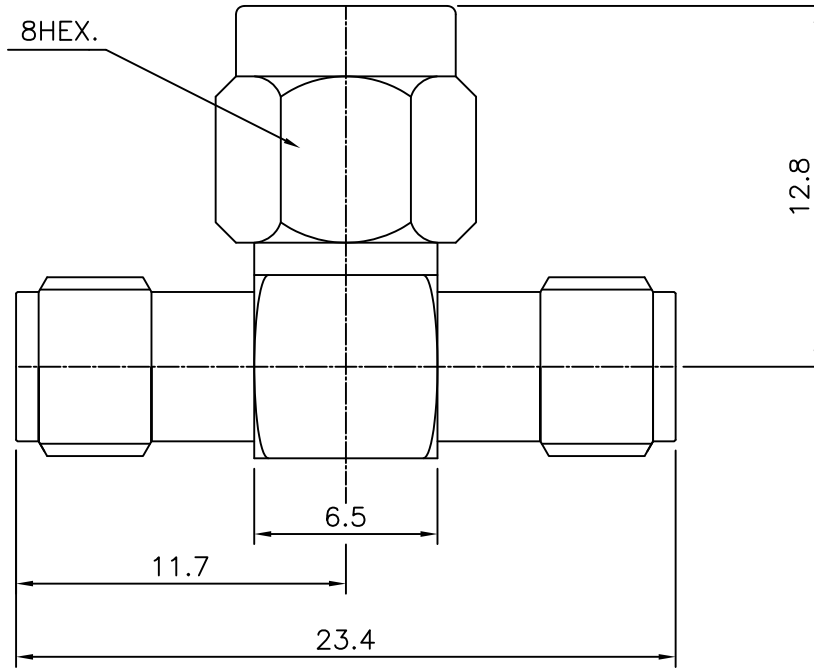

SMA T-ADAPTOR
JACK-PLUG-JACK

Connector parts	Materials	Finish
Coupling Cap	Brass	Gold plated
Body	Brass	Gold plated
Center contact	Beryllium copper	Gold plated
Insulator	Brass	
	PTFE	-

NO.	DESCRIPTION	Q'TY	MATERIAL	FINISH	REMARKS.
PARTS No.	SMA-807-002		NAME	SMA-T-JPJ Adaptor	APPROVED
MATERIAL	FINISH	TOLERANCES OTHERWISE SPEC. ±0.05		ANGLES ±1°	CHECKED
SCALE		UNIT	mm		DESIGNED S.J.LEE
DWG NO.		SMA-807-002		DATE. 2001.5/15	

CUSTOMER

