

1 2 3 4 5 6

No.	Revision	Date	Name
△			
△			

RoHS Compliant

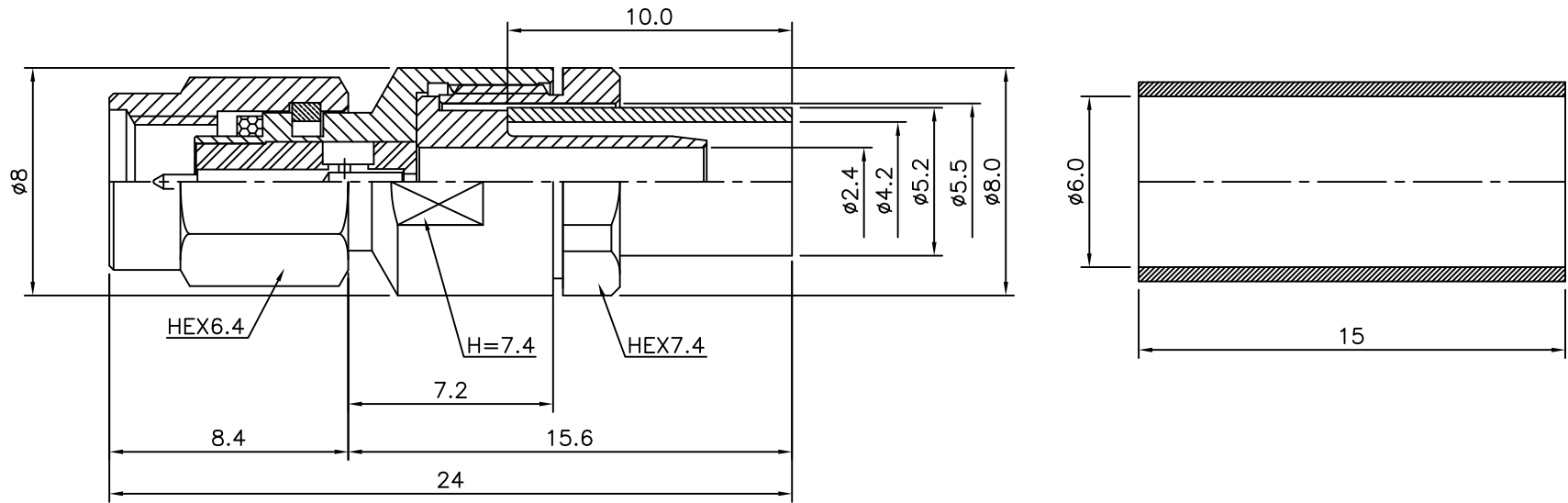

Connector parts	Materials	Finish
Coupling Cap	Stainless steel	Nickel Plated
Body	Stainless steel	Nickel Plated
Center contact	Brass	Gold Plated
Ferrule	Brass	Nickel Plated
Insulator	PTFE	-
Gasket	Silicone rubber	-
HEAT SHRINK TUBE	-	-

SSMA-Stright-PLUG
for Cable:7501A (750Hm)

CUSTOMER

NO.	DESCRIPTION	Q'TY	MATERIAL	FINISH	REMARKS.
PARTS No.	SSMA-111-007	NAME	SSMA-SP-7501A		APPROVED
MATERIAL	FINISH	TOLERANCES OTHERWISE SPEC. ±0.05		ANGLES ±1°	CHECKED
SCALE N/S		UNIT mm			DESIGNED S.J.LEE
		DWG NO. SSMA-111-007		DATE. 24/JUN/2012	