

No.	Revision	Date	Name
△	PN Change from 1MB-502-M7209	25/09/2013	B.G.YUN
△			

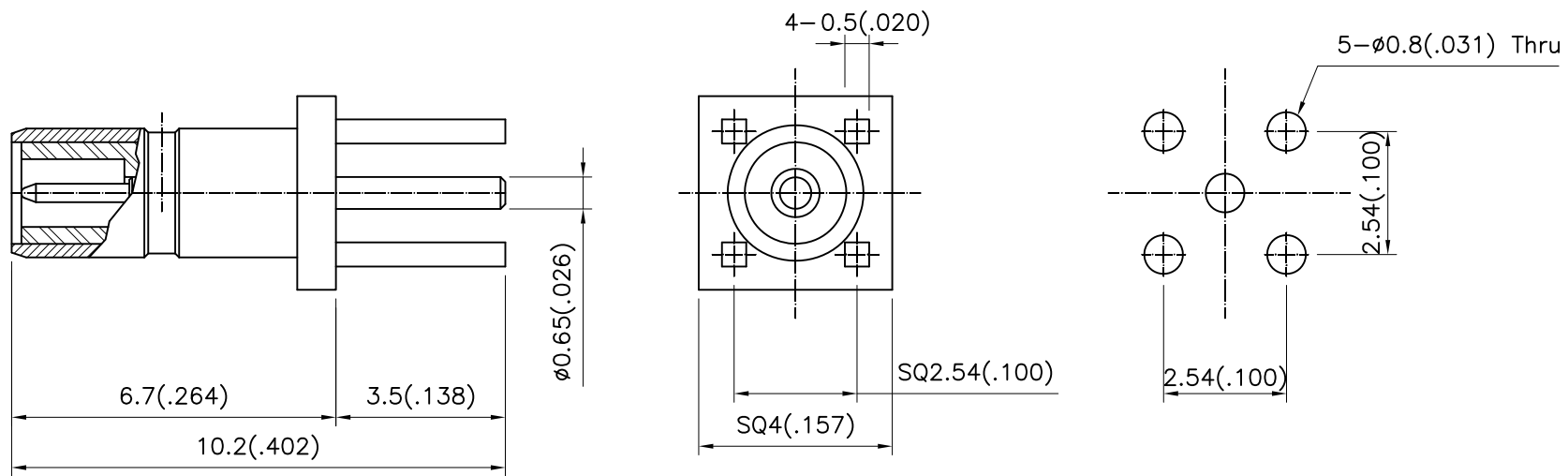

MATERIALS

- 1.BODY= BRASS
- 2.INSULATOR= TEFLON
- 3.CONTACT= BERYLLIUM COPPER

FINISH

- 1.BODY= GOLD PLATER PER MIL-G-45204, TYPE II, CLASS 0, GRADE C, OVER .00020 COPPER STRIKE PER MIL-C-47550
- 2.CONTACT= GOLD PLATE PER MIL-G-45204, TYPE II, CLASS 1, GRADE C, OVER .00010 TO .00020 STRESS FREE SULFAMATE NICKEL PER QQ-N-290

SSMB Straight JACK
P.C.B. MOUNT RECEPTACLE

NO.	DESCRIPTION	Q'TY	MATERIAL	FINISH	REMARKS.
PARTS No.	SSMB-602-002		NAME	SSMB SJ PCB	APPROVED S.J.LEE
MATERIAL	FINISH	TOLERANCES OTHERWISE SPEC. ±0.05		ANGLES ±1°	CHECKED
CUSTOMER 		SCALE	UNIT mm		DESIGNED S.J.PARK
		DWG NO.	SSMB-602-002		DATE. 08/MAR/2013