

1	2	3	4	5	6
SPECIFICATIONS			No.	Revision	Date
1. Impedance : 50Ω			△		
2. Frequency range : DC~4.0GHz			△		
3. Contact current : DC 3.5A max.					
4. Voltage rating : 250Vrms					
5. Contact resistance : Center contacts : 2.0mΩ					
Outer contacts : 0.2mΩ					
6. Insulation resistance : 5,000MΩmin.					
7. Temperature Range : -65°C ~ +165°C					
8. V.S.W.R : ≤=1.25					

D  
C  
B  
A

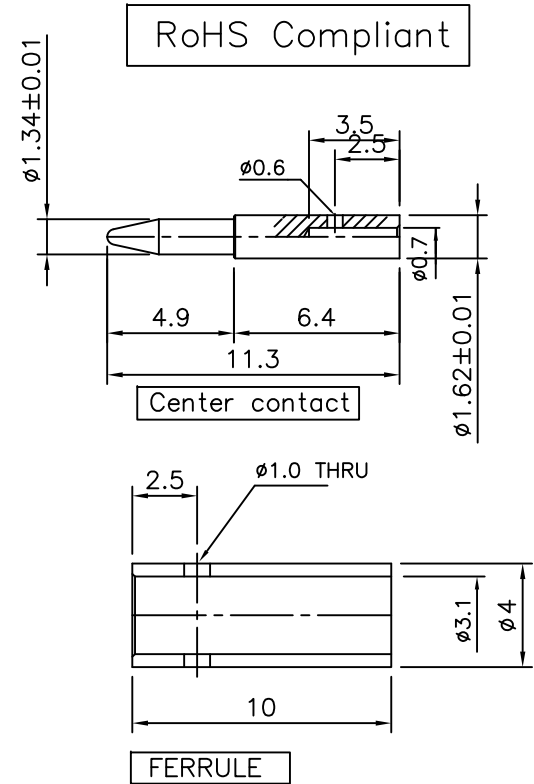
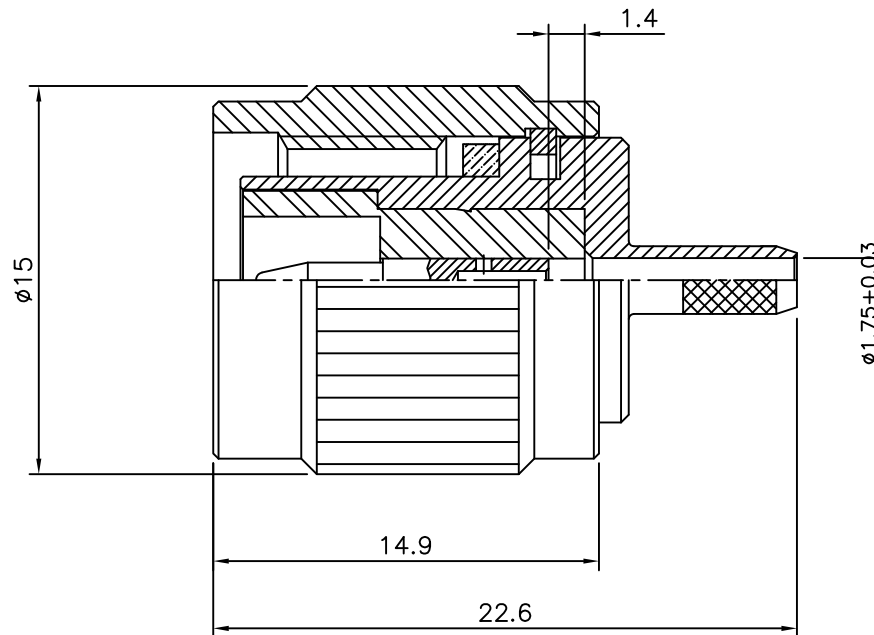

TNC-Straight-PLUG  
for Cable:RG316

Connector parts	Materials	Finish
Coupling Cap	Brass	Nickel Plated
Body	Brass	Nickel Plated
Center contact	Brass	Gold Plated
Ferrule	Brass	Nickel Plated
Insulator	PTFE	-
Gasket	Silicon rubber	-

CUSTOMER

NO.	DESCRIPTION	Q'TY	MATERIAL	FINISH	REMARKS.
PARTS No.	TNC-111-004	NAME	TNC-ST-P316		APPROVED
MATERIAL	FINISH	TOLERANCES	OTHERWISE SPEC. ±0.05 ANGLES ±1°		CHECKED
SCALE	UNIT	mm		DESIGNED	S.J.LEE
DWG NO.	TNC-111-004		DATE.		05/JUL/2012



DONGJIN TI.