

No.	Revision	Date	Name
△	PN Change from 1T-314-04SF	18/DEC/2013	S.J.PARK
△			

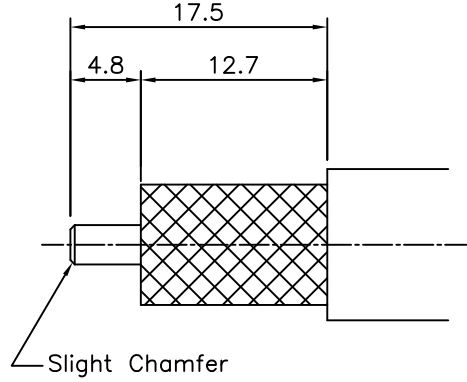
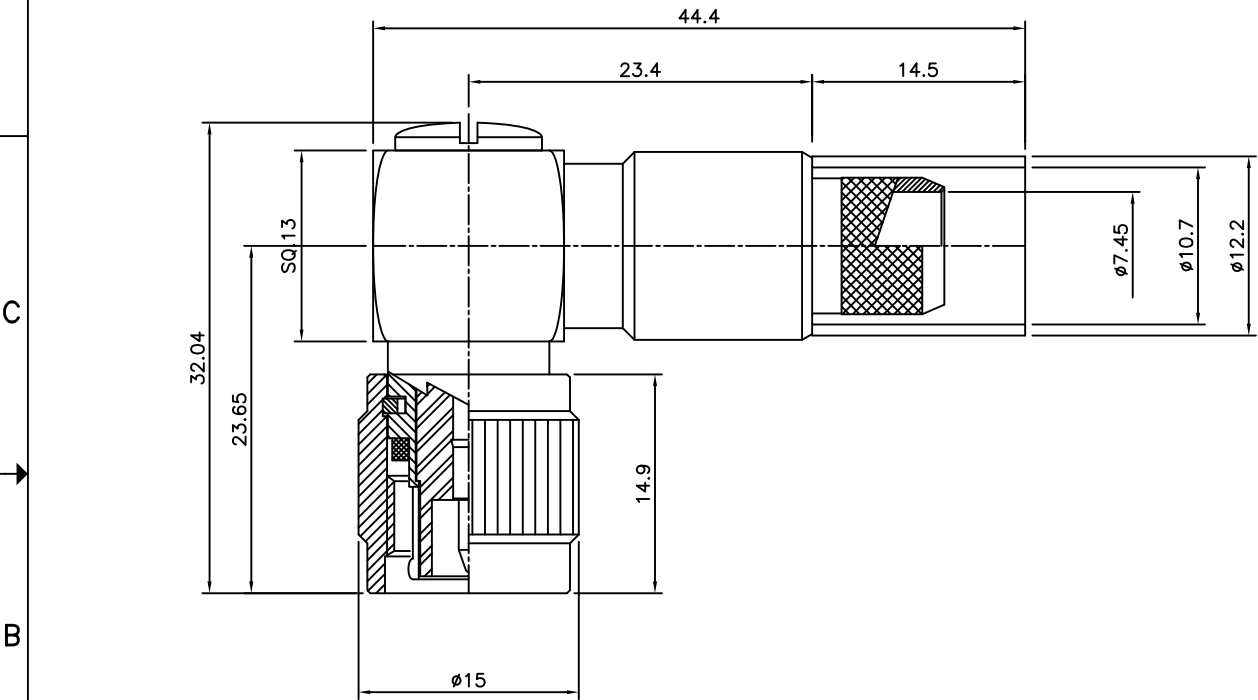

Slight Chamfer

Recommended Stripping DIM'S

Recommended Crimp DIES : HEX10.7

TNC Right anle Plug(No-solder) for LMR400/RG 8
Crimp Outer/Spring Finger Center

Connector parts	Materials	Finish
Coupling Cap	Brass	Nickel Plated
Body	Brass	Nickel Plated
Center contact	Beryllium copper	Gold Plated
Ferrule	Brass	Nickel Plated
Insulator	PTFE	-
Gasket	Silicone Rubber	-

NO.	DESCRIPTION	Q'TY	MATERIAL	FINISH	REMARKS.
PARTS No.	TNC-314-001		NAME	TNC-LP-LMR400 CRIMP	APPROVED
MATERIAL	FINISH	TOLERANCES		CHECKED	
		OTHERWISE SPEC. ±0.05 ANGLES ±1°			
		SCALE	UNIT	DESIGNED	
		N/S	mm	S.J. LEE	
		DWG NO.	DATE.		
		TNC-314-001	2002/11/15		

