

4	5	6	
No.	Revision	Date	Name
△1	PN Change from 1T-601-6030	13/MAR/2014	S.J.PARK
△			

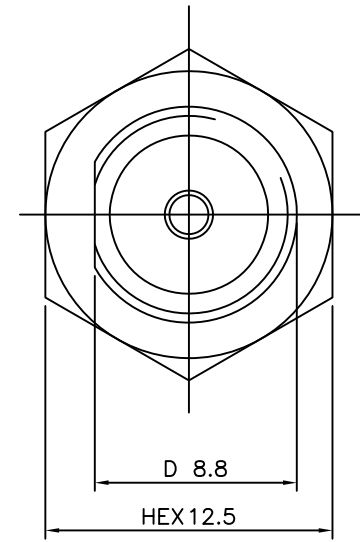
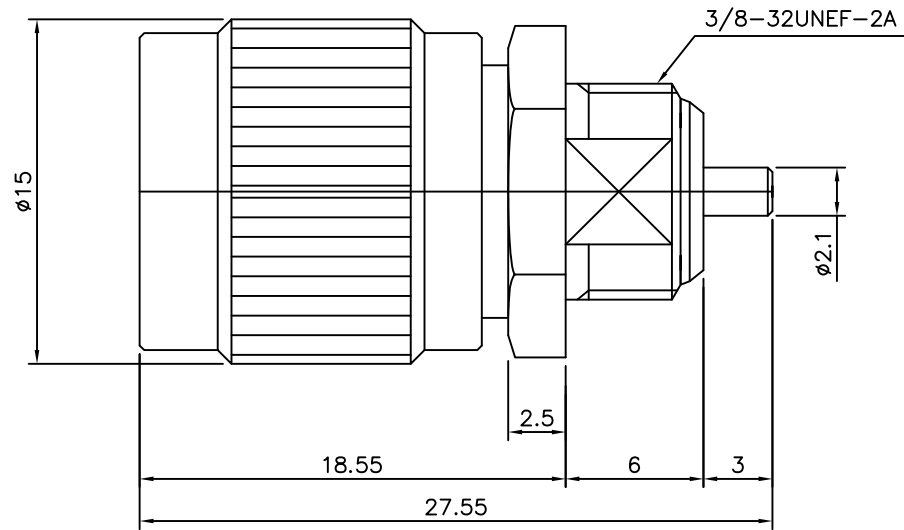

Item	Materials	Plating
Body, Coupling	Brass	Nickel Plated
Center contact	Brass	Gold Plated
Insulator	TEFLON	-

TNC-Bulkhead-PLUG Receptacle

NO.	DESCRIPTION	Q'TY	MATERIAL	FINISH	REMARKS.
PARTS No.	TNC-505-001	NAME	TNC-BR-P Recep.		APPROVED
MATERIAL	FINISH	TOLERANCES OTHERWISE SPEC. ±0.05		ANGLES ±1°	CHECKED
SCALE		UNIT	mm		DESIGNED S.J.LEE
DWG NO.		TNC-505-001		DATE.	04/03/2004

CUSTOMER

