

4	5	6	
No.	Revision	Date	Name
1	PN Change from 1T-804-02	14/MAR/2014	S.J.PARK
2			

RoHS Compliant

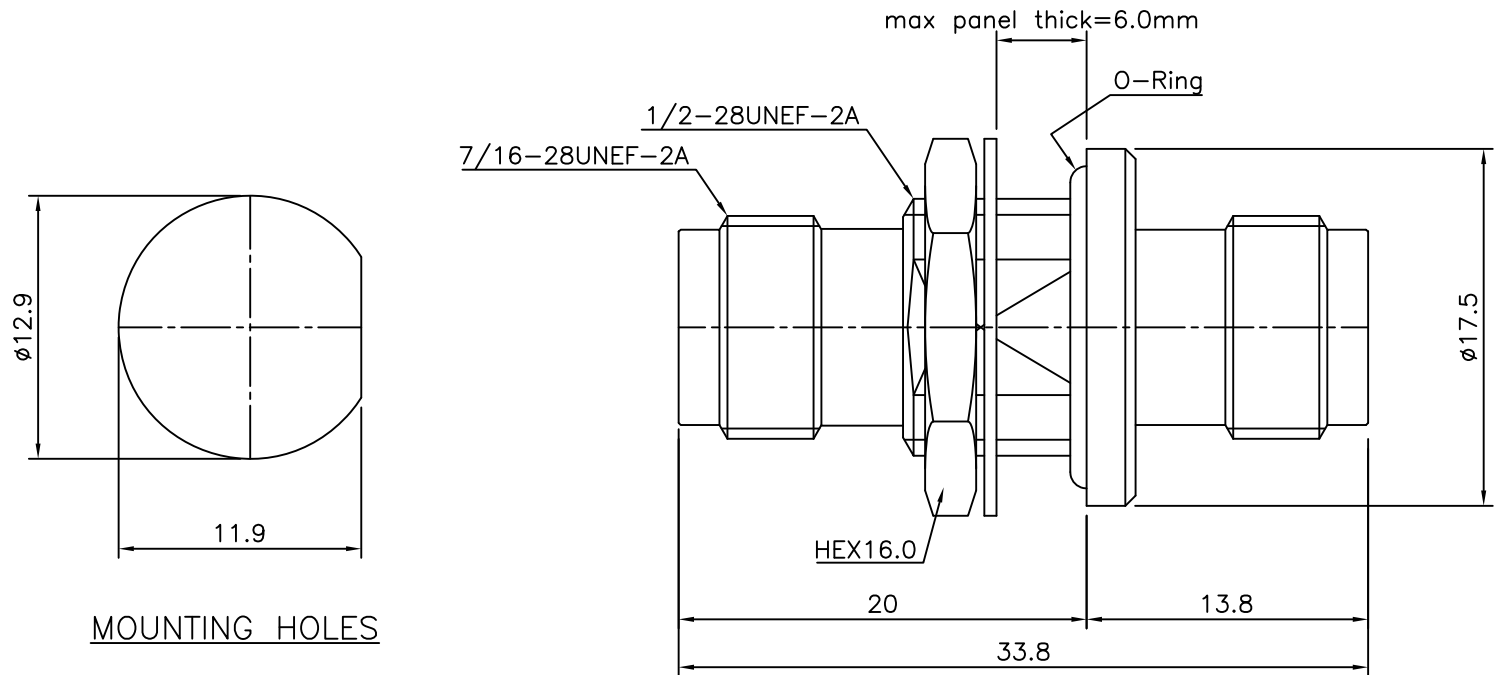

MOUNTING HOLES

Item	Materials	Plating
Body,Nut,Washer	Brass	Nickel Plated
Center contact	Be-Cu	Gold Plated
Insulator	PTFE	-
O-Ring	Silicone rubber	-

TNC-Bulkhead JACK to JACK ADAPTOR-with SEAL(IP67)

NO.	DESCRIPTION	Q'TY	MATERIAL	FINISH	REMARKS.
PARTS No.	TNC-804-001	NAME	TNC-B/H-JJ Adap.		APPROVED
MATERIAL	FINISH	TOLERANCES OTHERWISE SPEC. ±0.05		ANGLES ±1°	CHECKED
SCALE		UNIT	mm		DESIGNED S.J.LEE
DWG NO.		TNC-804-001		DATE.	03/MAR/2008

CUSTOMER

