

4	No.	Revision	Date	Name
	△	PN Change from 1T-882-00	14/MAR/2014	S.J.PARK
	△			

RoHS Compliant

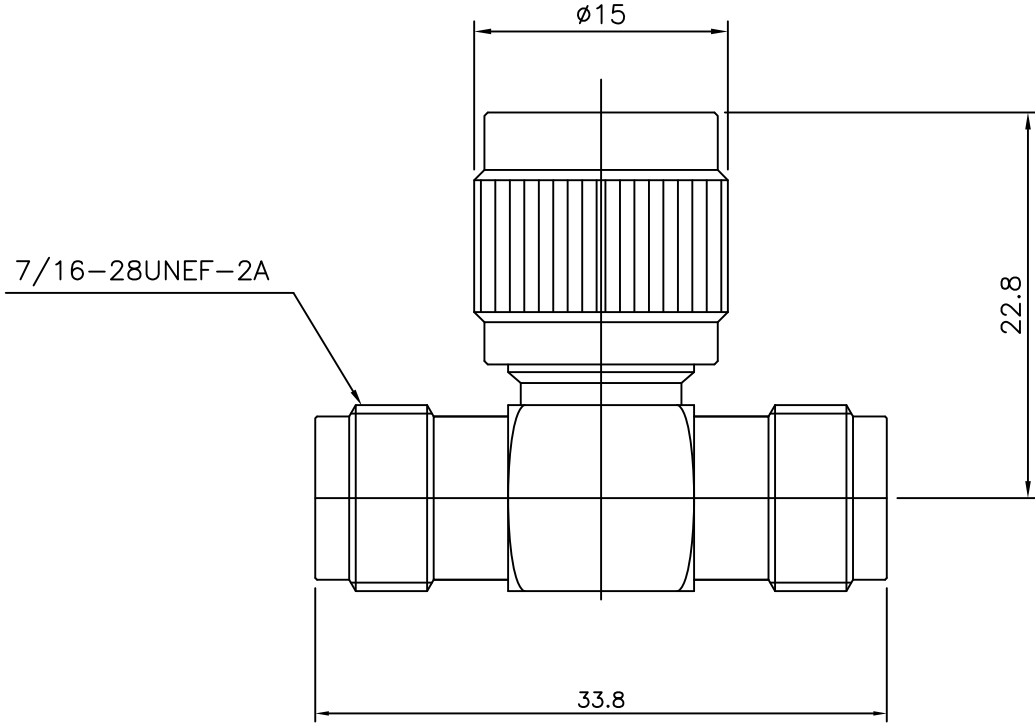

TNC T-JACK-PLUG-JACK ADAPTOR

Item	Materials	Plating
Coupling cap	Brass	Nickel Plated
Body	Brass	Nickel Plated
Center contact	Beryllium copper	Gold Plated
Insulator	Brass PTFE	-

CUSTOMER

NO.	DESCRIPTION	Q'TY	MATERIAL	FINISH	REMARKS.
PARTS No.	TNC-807-001	NAME	TNC-T-JPJ-Adap		APPROVED
MATERIAL	FINISH	TOLERANCES OTHERWISE SPEC. ±0.05		ANGLES ±1°	CHECKED
		SCALE	UNIT mm		DESIGNED S.J.LEE
		DWG NO.	TNC-807-001		DATE. 12/JUL/2013